

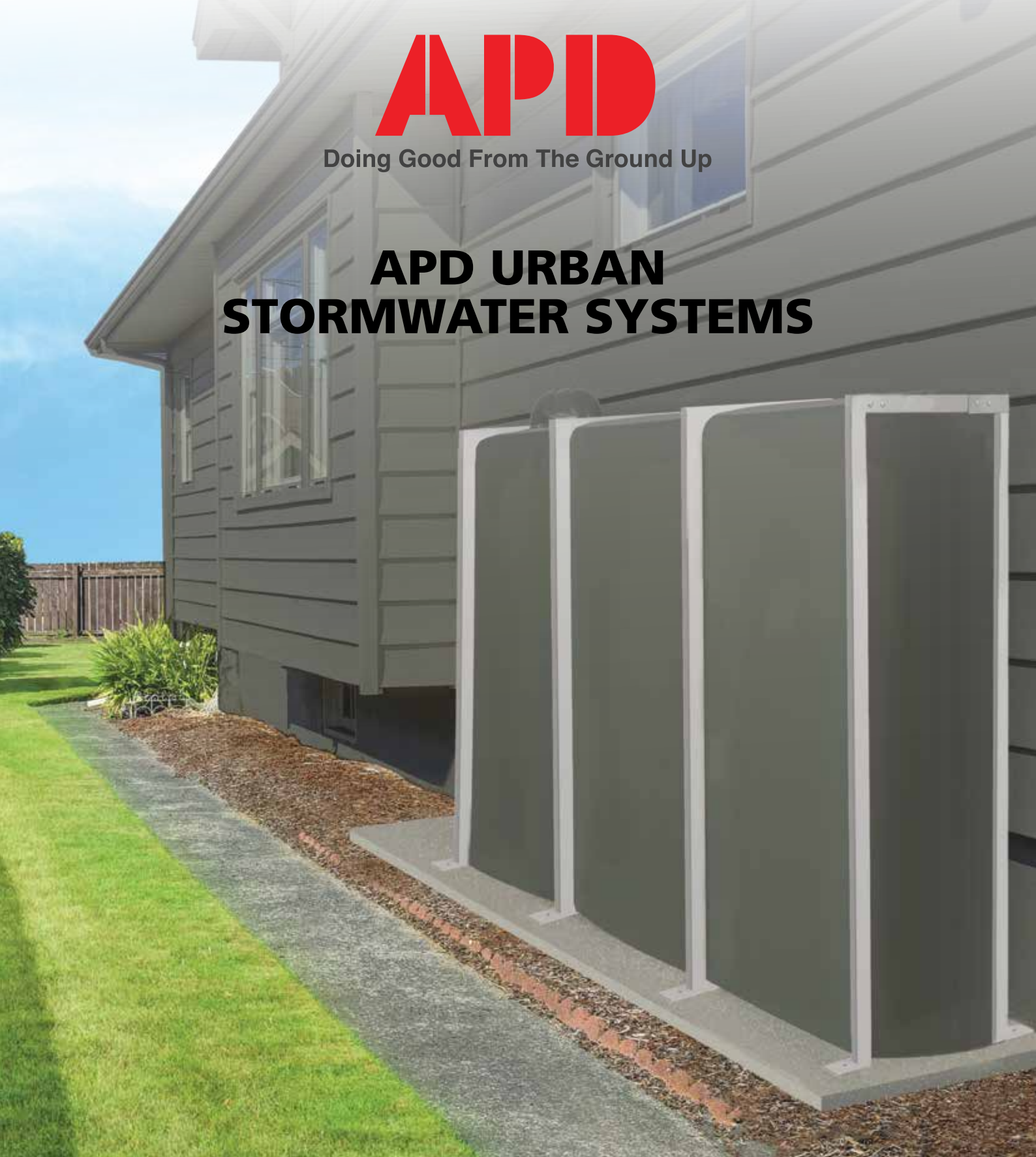

Doing Good From The Ground Up

# APD URBAN STORMWATER SYSTEMS



For more information call (09) 263 7741

[www.apd.co.nz](http://www.apd.co.nz)

**APD**

**Doing Good From The Ground Up**

[www.apd.co.nz](http://www.apd.co.nz)

# It's easy to find your ideal tank solution at APD.

Make finding your tank requirements easy with APD. We're here to help you from start to finish - from customer service, to national representatives, to technical support, our team of experts will help scope out your requirements and find out about your specific needs to provide a solution that's perfect for you. With a proven track record, we pride ourselves on our friendly, quality service.

Designed and manufactured in Auckland, New Zealand by APD Ltd, our range of tank and system solutions for above and below ground will ensure whatever your requirement - whether it's for Stormwater Detention, Rainwater Harvesting or Chemical Storage and Binding - you can be sure you'll find exactly what you need right here.

**CALL APD, AND FIND YOUR IDEAL TANK SOLUTION NOW ON (09) 263 7741.**

## CONTENTS

StormLite Underground Cylindrical Tanks	4-5
StormSlim® Above Ground Tanks	6-7
StormSlab Tanks	8-9
RainWorx Rain Harvesting Systems	10-11
StormLite Above Ground Rectangular Tanks	12
Above Ground Cylindrical Tanks	13
StormLite <sup>3</sup> Underground Rectangular Tanks	14-15
StomWorx Pump Station	16-17
StormPit Surface Water Sumps	18-21
StormPit Bubble Up Chamber	22-23
Notes	24-27

### THE APD PRODUCT RANGE INCLUDES:

- Underground Water Retention/ Detention Systems
- Above Ground Water Retention/ Detention Systems
- Rain Harvesting Systems
- Chemical Storage Tanks
- Open Top Process Tanks
- Surface Water Sumps and Bubble Up Chambers
- Boat and RV Tanks
- HVAC Ducting suitable for chemical applications and council swimming pool environments
- Piping Systems for chemical, water and waste water plants



**Made to Order Economy.**

Our 1200 diameter tanks are made from a potable grade polyethylene, which means they can be used for drinking water.

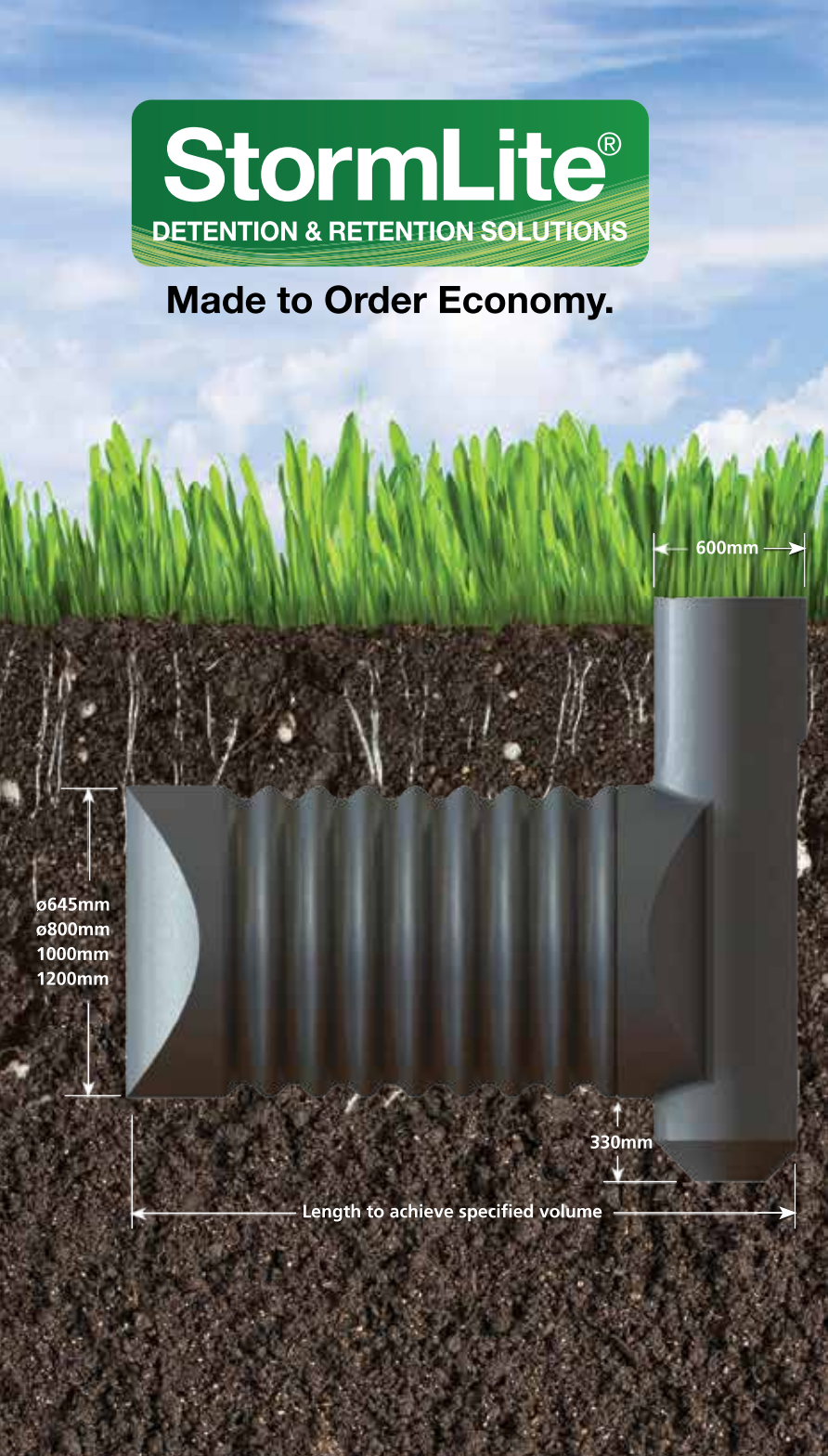

**EASY INSTALLATION**

All APD StormLite tanks come with a full fittings kit-set consisting of three wallace seals, end cap and leaf trap mesh. The engineered riser shape with flat back panel ensures simple installation of the wallace seals and our lightweight robust design means that APD tanks are easily and safely lifted into place with a digger on site.

**CHOOSE FROM FOUR DIAMETER OPTIONS**

APD provides tanks in 1200mm, 1000mm, 800mm and 645mm to suit your site depth requirements.

**DON'T PAY FOR EXTRA VOLUME YOU DON'T NEED**

All APD StormLite tanks are assembled to the exact volume required and delivered within 2-5 days to site by hiab truck.

**TANK ACCESSORIES**

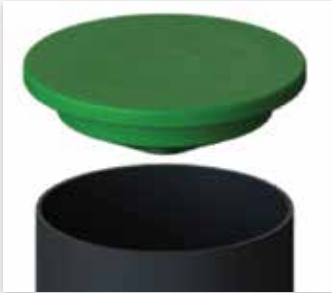

Garden Lid



Adjustment ring for driveway or concrete install

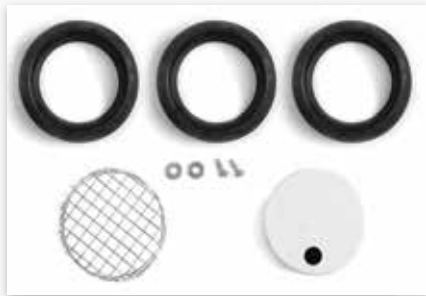

Standard 100mm fittings kit (150mm available on request)

For more information call (09) 263 7741

[www.apd.co.nz](http://www.apd.co.nz)

## THE ECONOMICAL CHOICE, MADE LIGHT AND STRONG

At around 250 kilograms, a 5000 litre StormLite® water tank is a mere fraction of the weight of concrete tanks. This means it can be moved around site with only a small digger. Designed strong, StormLite can go under driveways, carparks, and grass. Tell us your volume requirement, and our make-to-order service will ensure your StormLite tank adheres to council regulations, while making your drainlayer's job a breeze. Make the affordable choice, with made to order economy. Call APD now on (09) 263 7741.



## TANKS THAT LAST

StormLite tanks are made from tough polyethylene corrugated pipe which won't corrode and can be recycled.

APD also provides StormLite tanks with a 10 year guarantee\* and 50 year design life.

\*10 year guarantee subject to APD Terms and Conditions of Trade.

## OUT OF SIGHT

Save precious outdoor space on your section and eliminate the intrusive visual impact of an above ground tank. StormLite tanks are buried out of sight and can be installed under driveways, gardens or lawns.

## HAMMERHEAD DESIGN

APD's unique hammerhead design with built in silt trap eliminates the cost associated with the installation of a separate silt trap and ensures 100% of the tank capacity can be utilised, avoiding the need for a larger tank. Connections can also be made into the opposite end of the tank if needed.

We can also provide pre-welded spigots to join multiple tanks together and spigots for larger pipe connections.

## TANK ACCESSORIES



Optional pre-welded connecting and joining spigots

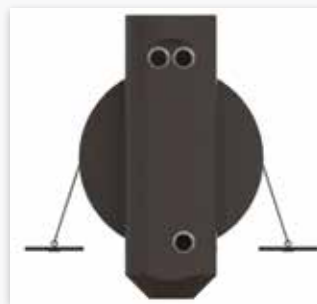

Optional Anti-Buoyancy Ground Anchors

For more information call (09) 263 7741

[www.apd.co.nz](http://www.apd.co.nz)

# StormSlim®

DETENTION & RETENTION SOLUTIONS

The Compact Home System.



## THE APD STORMSLIM® SYSTEM IS THE PERFECT ABOVE GROUND TANK OPTION FOR COMPACT SPACES!

StormSlim® is an innovative stormwater detention and retention system designed to manage your rainwater and stormwater when outdoor space is at a premium. StormSlim®'s compact dimensions and height means you can maximise the use of the outdoor space available without the visual impact of unsightly tanks. Designed to effortlessly and elegantly fit in with the exterior of your home whether retrofitting or a new build.

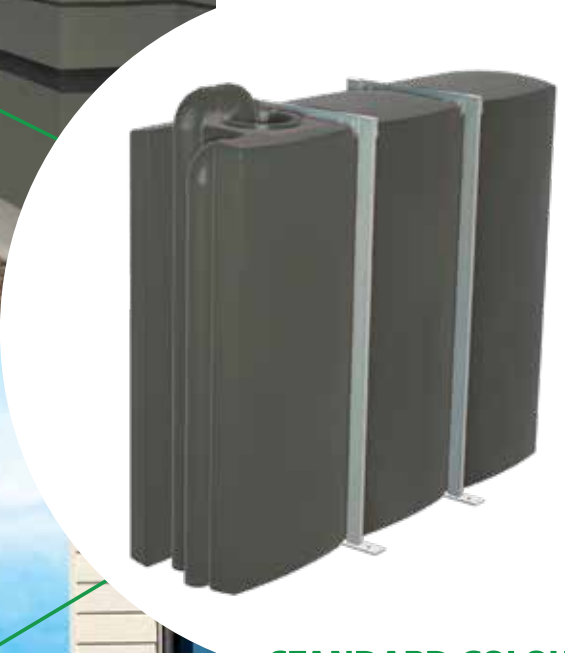

**CHOOSE FROM A RANGE OF COLOURS!**

### STANDARD COLOURS



70  
Black



89  
Slate Grey



817  
Light Grey



916  
Beige



206  
Mist Green

**ADDITIONAL COLOURS ARE AVAILABLE, MADE TO ORDER. STANDARD LEAD TIMES AND CHARGES APPLY. PLEASE CONTACT US TO FIND OUT MORE.**

## DESIGNED TO SUIT YOUR HOME

APD's StormSlim® tanks come in a variety of designer colours to perfectly match or complement your home. Whether you choose to match the tank colour to your house or fence, or opt for a bright pop of colour as a design feature, there's a colour option to suit.

## CONCEALED AND OUT OF SIGHT

Prefer to conceal your tank? APD's StormSlim® tanks can be housed in cladding or fencing by simply fixing framework to the galvanised support frames. Ask us about our optional framing kit to allow concealing the ends of the tank. The 2000, 3000, and 5000 litre StormSlim® tanks also come with a recessed end to help conceal the pipework.

## FEATURES

- New modular sizing minimises footprint.
- Multiple tank sizes to suit any design, including 1000, 2000, 3000, and 5000 litre options.
- PS1 for engineered residential slab designs available.
- All tanks are 1800mm high to match standard fence requirements.
- Manufactured to AS/NZS 4766:2020 from water tank grade PE material suitable for potable water.
- Designed and made in New Zealand for local conditions.
- Compatible with APD RainWorx systems and pumps.
- Engineered to meet the seismic requirements of Zone 1, 2 and 3, Wind Zone NZ1/NZ2, and Soils A-D.

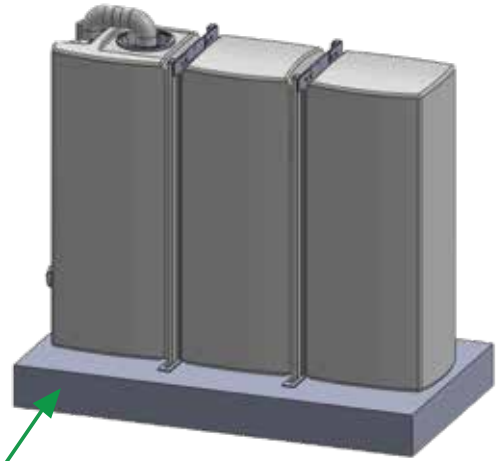

Seismic base slab



Framing kit



**TANK  
HEIGHT  
ONLY 1.8M**

Tank Size	Height (mm)	Width (mm)	Length (mm)	Slab Width (mm)	Slab Depth (mm)	Slab Length (mm)
1000 Litre	1800	360	2285	790	150	2400
2000 Litre	1800	640	2285	1073	200	2400
3000 Litre	1800	640	3400	1073	200	3500
5000 Litre	1800	1000	3400	1433	200	3500

For more information call (09) 263 7741

[www.apd.co.nz](http://www.apd.co.nz)



**Underfloor Peace of Mind.**



**WINNER**  
**NZ Plumbing Awards 2022**  
**PRODUCT OF THE YEAR**

**THE APD STORMSLAB IS A VERSATILE SYSTEM FOR RESTRICTIVE SITES!**

StormSlab is an innovative stormwater detention and retention system designed to manage rainwater and stormwater when site restrictions mean that our market-leading StormLite underground detention and retention solutions cannot be used. These restrictions are usually due to a lack of space and/or insufficient fall to the public stormwater system on the site.

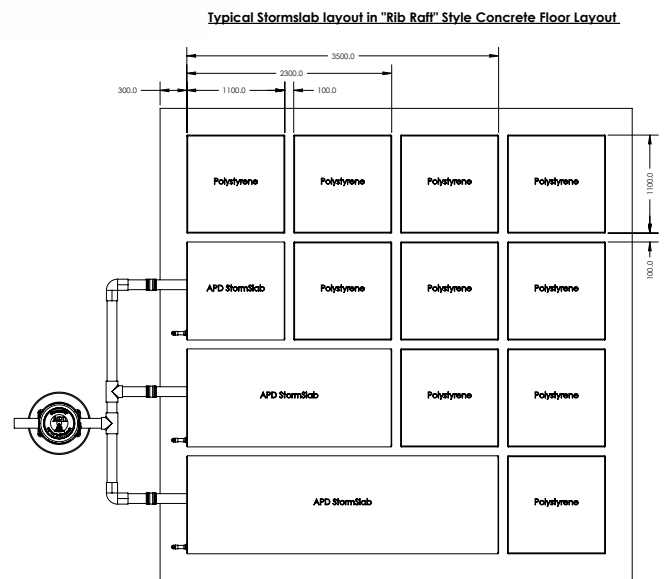
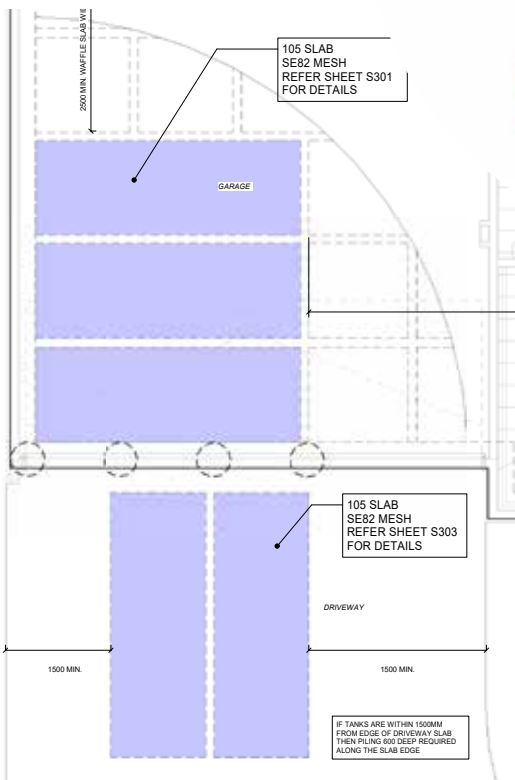
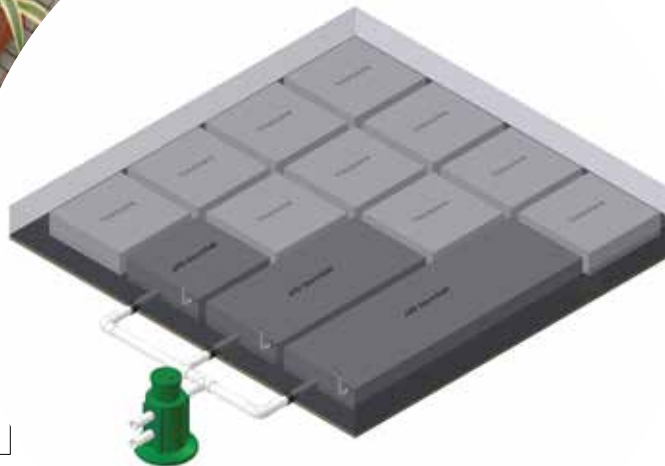

For more information call (09) 263 7741  
[www.apd.co.nz](http://www.apd.co.nz)



## COMPATIBLE WITH APD'S RANGE OF SOLUTIONS

Our StormSlab system can be coupled with the APD RainWorx rain harvesting below ground application for water reuse, while the APD StormSlab Distribution Chamber can also be used as a pump station (including three wall seals, a 100mm PVC cap, and mesh).

### FEATURES:

- No connections between StormSlabs under the slab.
- Multiple StormSlab sizes to suit any site or design.
- PS1 for engineered residential slab designs available.
- All StormSlabs are 1100mm wide to match standard pod configurations.
- Manufactured from water tank grade PE material suitable for below ground installation.
- Designed and made in New Zealand for local conditions.
- 300mm deep for extra storage.
- 220mm deep to match polystyrene pods.
- Garden & pavement (Ductile Iron) lids available for the Distribution Chamber.

**GREAT  
SPACE  
SAVER!**



APD StormSlab Distribution Chamber

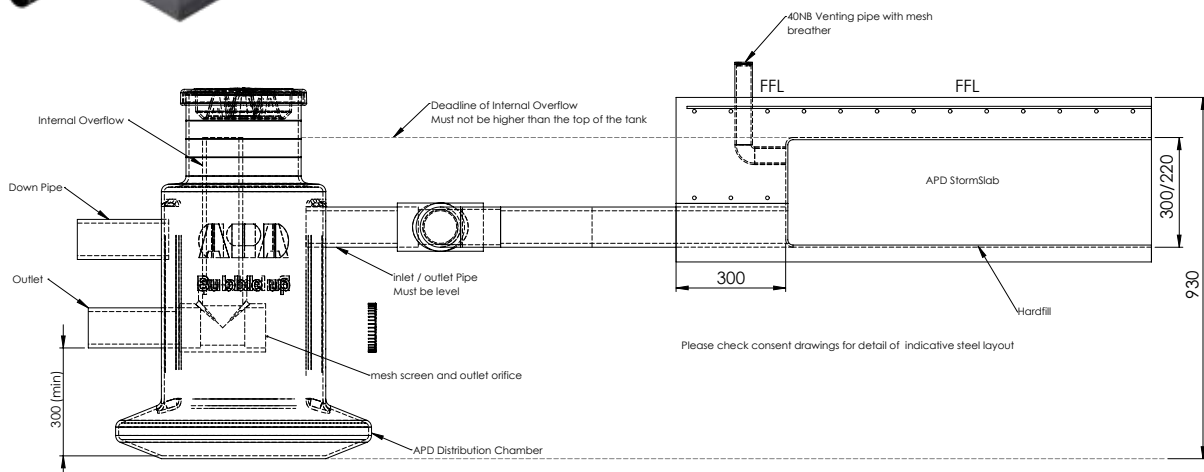



## The Easy, Complete System.

### THE RAINWORX® RANGE GIVES YOU:

**Complete package:** Along with the StormLite tank we supply the pumps, controllers, pipe work and covers ready to connect to your plumbing and to integrate with the public water supply.

**Quality parts:** We are NZ's leading plastic tank fabricators, providing the highest quality products. All our StormLite tanks come with a design life of 50 years and our quality tank design offers long term peace of mind with maximised service life for all parts.

**Flexible options:** Every household's needs are unique and because our tanks are made to order you can have the right set up tailored for you. You only pay for what you need.



**Efficient and intelligent system:** APD RainWorx Systems automatically switch to mains pressure water if the retention tank is empty or if mains power fails. Our unique tank design means 100% of the tank capacity is used while still meeting council requirements.

**Ready when you want it:** Made to order in just 2-5 days.

### RAINWORX FOR STORMLITE UNDERGROUND TANKS

Whether you have a modern urban home or a classic villa, whatever your needs, we have the right solution for you. APD RainWorx systems for StormLite underground tanks include pre-fitted internal pipework and pump platform, plus submersible pump and wall mounted RainWorx cabinet.

#### APD's exclusive tank design comes with:

- Pre-fitted internal pipework – Avoiding the hassle and Health & Safety risks of trademen entering confined spaces for installation.
- Pump platform – Prevents the pump from sitting in the silt trap to ensure only clean water is pumped into the house.

For more information call (09) 263 7741

[www.apd.co.nz](http://www.apd.co.nz)

## THE IDEAL RAIN HARVESTING SOLUTION IS EASY

You'll never run out of water, using APD's smart RainWorx system. It automatically switches to mains supply once storage levels become low enough, or when there is a power cut. This unique system comes in a ready-to-go package, with options to suit above and below ground tanks, we'll even provide a template for the plumber and electrician for a simple installation. Start using free water. **Get the easy, complete system from APD now on (09) 263 7741.**

## INSTALLING A STORMWATER DETENTION TANK TO MEET COUNCIL REQUIREMENTS

The APD RainWorx System harvests and recycles your valuable rainwater for toilets, washing clothes, watering the garden and washing your car.

With the tank installed underground, usable outdoor space is maximised and visible obstruction is removed.

Fast installation saves costly additional man hours on site, keeping the time spent in the excavation site to a minimum; making for a safer and efficient work environment.

APD can provide customised commercial packages for medium to large scale jobs: Apartment Complexes, Residential Developments etc.

## RAINWORX SYSTEM PACKAGES

- Packages to suit underground or above ground tanks.
- User friendly status monitors.
- Back flow protector (double check valve).
- Inline filter, all fittings and bracketing.
- Isolation valves.
- Custom packages available on request.

## RAINWORX PUMP KITS FOR UNDERGROUND TANKS



Pre-Fitted Internal Pipework

Exclusive Design Pump Platform

Silt Trap

*Submersible Pump Option + Tank Internal Pipework & Pump Platform*



*Pre-Assembled RainWorx Cabinet - Wall Mountable*

## RAINWORX PUMP KITS FOR ABOVE GROUND TANKS



*Surface Mounted Pump With Cover*

*Pre-Assembled RainWorx Cabinet - Wall Mountable*

For more information call (09) 263 7741

[www.apd.co.nz](http://www.apd.co.nz)



Made to Order Economy.

# StormLite® Rectangular

## ABOVE GROUND DETENTION/RETENTION TANKS

Above ground Rectangular tanks are available from APD for those projects where standard detention tanks just won't work. Great for placing under houses and decks, these tanks can be custom made to fit between piles and structural supports.

### DIMENSIONS

Standard height is up to 800mm. Both the width and length of our rectangular tanks can be sized to suit the site requirements.



### SIMPLE INSTALLATION

No ground excavation is required other than levelling and compacting the area where the tank is to be sited, assuming site soil meets the requirements of NZS3604:2011 classification of 'Good Ground'.

### OPTIONS

APD offers a choice of lid types to suit installation. There is also an optional addition of silt traps and optional re-positioning of a man way.

We can also include access and risers if required.

*See below for examples.*

### SPECIALIST DESIGN THAT LASTS

The APD rectangular StormLite tank was specifically engineered by our in-house team based on international standards for fabricated tanks.

Made from heavy duty polyethylene sheet, with internal baffles for added strength and support, the tank has been optimised to provide a robust solution.

### OPTIONS

1. Standard man way position



2. Optional man way position



3. Silt trap and custom lid



For more information call (09) 263 7741

[www.apd.co.nz](http://www.apd.co.nz)

# Custom Built Above Ground Tanks

## CYLINDRICAL TANKS - CUSTOM BUILT

Made to order tanks for special requirements.

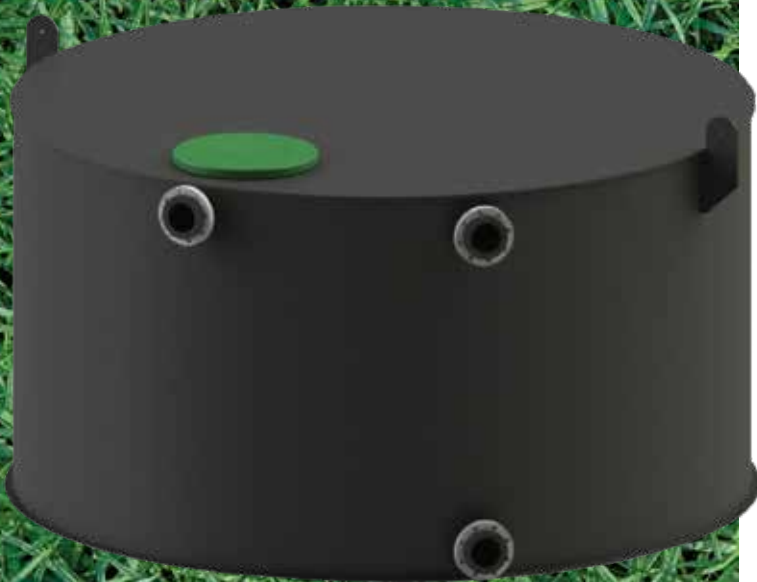

APD's above ground tanks can be used to store water for drinking, to support your bathroom water use or for watering the garden and can be manually filled for potable water or used in conjunction with RainWorx to collect rainwater runoff from your home.

## INTELLIGENT DESIGN

Our designs allow quick, straight forward installation of the tank, reducing cost and the need for multiple contractors.

The tank can be easily moved to cater for future needs.

## 500L TO 60,000L CAPACITY

Depending upon your needs, APD's tanks can be designed and built up to at least 60,000L. Tanks can be used for detention, retention (rain harvesting), drinking water or any combination of the above.

## DESIGNED TO SUIT YOU

Because APD designs and builds to order, the tank will be built to the dimensions you require, rather than standard dimensions like other suppliers. All of APD's tanks are seismically rated so you have peace of mind the tank will endure whatever is thrown its way – speak to our helpful team to find out more.

## LONG LASTING

APD's tanks all have a 25 year service life and in some cases longer. The grade of material used will out perform all other tanks and won't crack, corrode or rot like other tank materials.

## FIXTURES AND FITTINGS

All of APD's tanks are provided with the fittings you require for your site. This can be multiple inlets and outlets and virtually any size. Our fittings are welded to the tank and reinforced as required so there is no chance of the fittings leaking. APD's tanks are all hydrostatically tested before being delivered to ensure you have a trouble free installation.

For more information call (09) 263 7741

[www.apd.co.nz](http://www.apd.co.nz)



## Modular Strength that Fits.

When you need underground stormwater detention or retention but are constrained by:

- Limited vertical depth to stormwater discharge point.
- Requirement for deep burial (up to 2m cover).
- Limited space that needs to store a large volume of water.

StormLite<sup>3</sup> does it all with its unique APD design.

### TRAFFICABLE

Designed to support loads up to 28 tonnes/sqm.

Solutions strong enough to support up to 2m of ground cover and/or withstand heavy traffic loads, so long as the overall 28 tonnes/sqm load limit is not exceeded.

### PROTECTIVE EXTERIOR SHELL FOR A SOLUTION THAT LASTS

As New Zealand's leading plastic tank fabricators we know what it takes to make a robust tank shell.

We've combined our expertise and high quality materials to produce a 6mm thick shell that securely holds the modular tank elements together and is over 7x the thickness of the protective layer used by other modular systems. Every weld on every tank is leak tested during production.

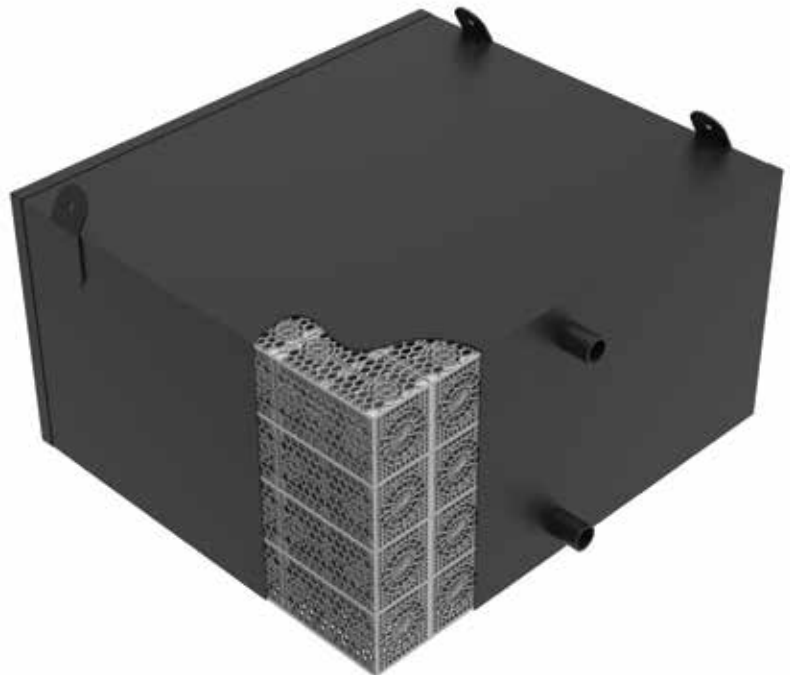

### CONNECTING SPIGOTS & INSPECTION PORTS

Standard with all StormLite<sup>3</sup> tanks are a tank connection spigot and a vent spigot for connection of the tank to a manhole chamber as shown in the illustration on the right.

**Add on options are:**

- Additional connection spigots at standard pipe diameters up to 300mm (315mm OD).
- Inspection ports up to 150mm diameter (160mm OD).
- Bore pumps and access ports up to 150mm diameter.

For more information call (09) 263 7741

[www.apd.co.nz](http://www.apd.co.nz)

## MODULAR SOLUTIONS, FOR WHEN IT HAS TO FIT

When your retention or detention tank has to fit underground, either very deep, in a shallow space, and/or for vehicles to drive over, APD's NEW StormLite<sup>3</sup> has your ideal solution. Its unique modular rectangular system is extremely durable and watertight, using the same reliable 6mm polyethylene sheet that is used on hazardous-rated chemical tanks. Installation has never been this easy, arriving on-site complete and ready-to-go. All you have to do is specify your requirements, then fill-in over the top of the highly durable delivered tank.

## ARRIVES PRE-ASSEMBLED

So it can be installed quickly and safely. Our StormLite<sup>3</sup> tank is delivered complete with spigots for an inlet and vent pipe ready to connect to a manhole.

Tanks are supplied standard with lifting lugs, to simplify handling on site.

Fast installation saves costly additional man hours on site, keeping the time spent in the excavation site to a minimum; making for a safer and efficient work environment.

StormLite<sup>3</sup> was developed because we were approached repeatedly by Engineers and Drainage Contractors for low vertical profile tanks, to be buried at depths greater than 1 metre and tanks to maximise volume storage in limited spaces.

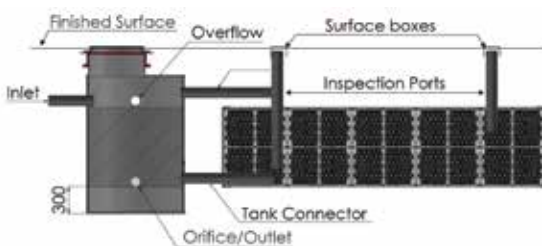

## MODULAR TANKS

Modular tanks that fit any environment and give you the flexibility you need.

The internal structure of StormLite<sup>3</sup> is composed of ProTank modules, arranged to utilise space effectively, fitting your volume requirements and site layout.

ProTank modules lock together vertically, up to 5 high, and pack together horizontally to form the shape of the tank.

## CONFIGURATION OPTIONS

**Minimum Tank Height:** 458mm (1 Module)

**Maximum Tank Height:** 2150mm (5 Modules)

**Maximum Buried Depth:** 3m from base of tank

**Maximum Cover Over Top of Tank:** 2m

**Maximum Tank Width:** Approx. 4500mm  
(Requires Special Transport)

Maximum Tank Length is dependent on the height and width. Please contact APD for advice.

**Minimum Cover to Finished Ground Level:**

Grass Install: 300mm

Driveway/Trafficable Install: 600mm

## MANHOLE CHAMBER AND SILT TRAP FOR DRAINAGE

The StormLite<sup>3</sup> tank must be connected to a manhole chamber as per the diagram, to limit silt intake into the tank and as a connection point for all inlets, overflow and orifice/outlet.

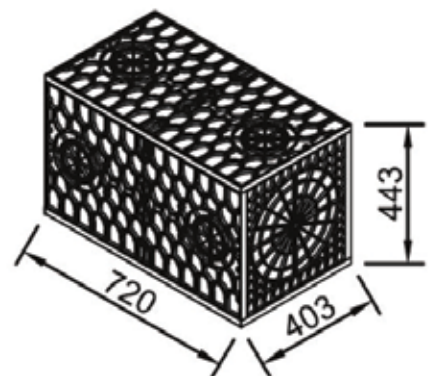

For more information call (09) 263 7741

[www.apd.co.nz](http://www.apd.co.nz)

Our latest generation pump chambers are the most versatile on the market. Versatile sizes and shape for ease in installation and provide anti-flotation, versatile lid options which are simply adjustable, versatile controllers increase pump life expectations, versatile quality pumps for every specification.

## VERSATILITY

- Full commissioning included.
- 700 and 1000 litre chamber sizes.
- Adjustable lids for easy installation.
- Garden and concrete or driveway lids available.
- Anti-flotation ring built in, no need for concrete around base.
- Chamber is 100% recyclable.
- Square shape minimises excavation.
- Manufactured to AS/NZ 4766:2020.

**VERSATILE  
ADJUSTABLE  
LID OPTIONS  
FOR LAWN  
AND  
PAVEMENT**





## PUMPS AND CONTROLLERS

- High quality American designed pumps.
- Oil filled motor for optimal heat dissipation: This design minimises concerns about the pump overheating or breaking down due to extreme heat generation during extended-use applications.
- Corrosion-resistant, powder coated epoxy finish.
- 100% factory tested: Our factory-tested vortex pumps ensure reliable performance in challenging applications with fewer concerns about mechanical failures.
- Automatic thermal overload protection (1 Phase).
- Non-clog Vortex Impellers with large 38-50mm solids handling capabilities.
- Legs provide for freestanding installation.
- State of the art controllers help protect the pump from burnout.
- Twin pumps options available.

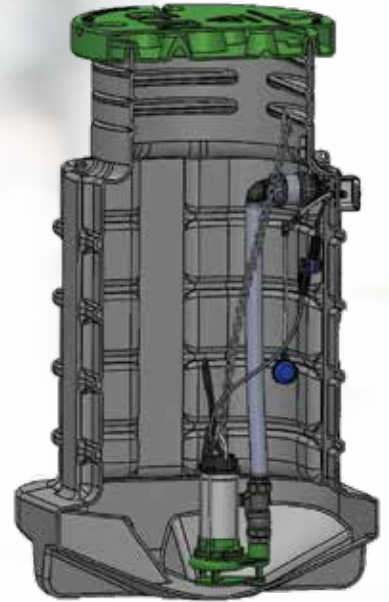

WU88 V



WU422 V



WU223 V

## Stormwater Range

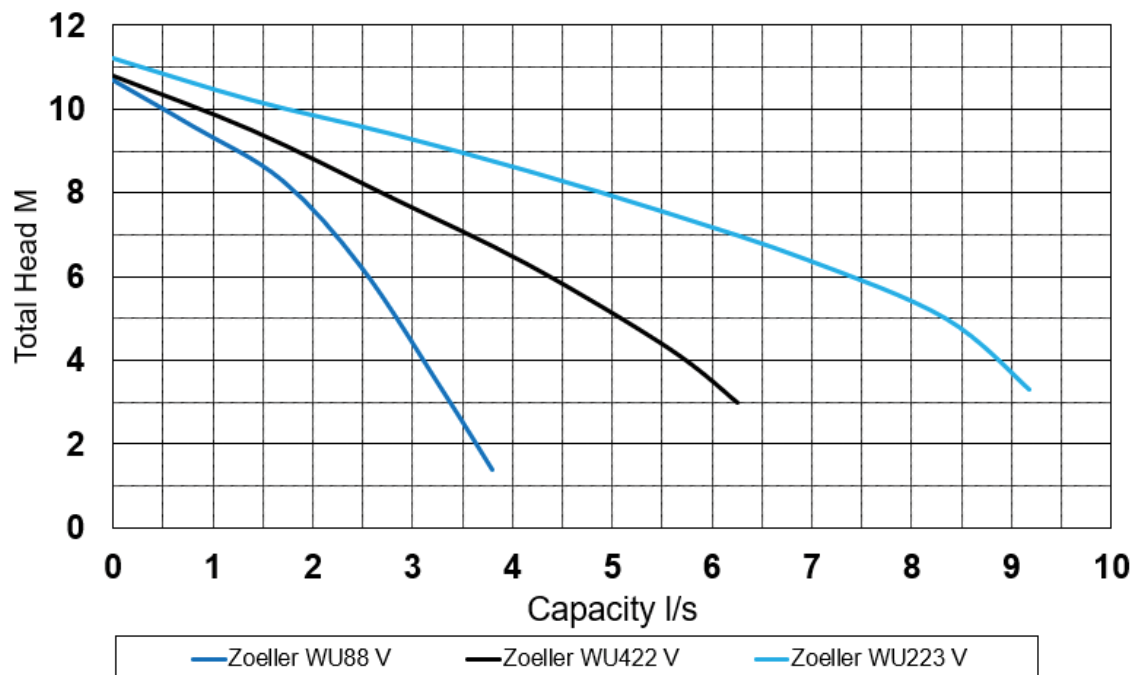

For more information call (09) 263 7741

[www.apd.co.nz](http://www.apd.co.nz)



**Built for Compliance.**

# StormPit Type One

**THE APD STORMPIT RANGE HAS IT ALL PLUS MORE!**

Don't be fooled by non-compliant sumps and ensure you are complying to 'NZ Building Code E1 Surface Water' by installing the APD StormPit Type One sump today.

**EASIER!  
FASTER!  
IMPROVED!**

## NZBC E1 TYPE ONE COMPLIANT SUMPS ARE REQUIRED TO HAVE

- 300mm opening.
- Maximum 1000mm height.
- 375mm diameter.
- Removable access cap for cleaning.
- A submerged or trapped outlet.
- 300mm minimum at base for silt settlement.
- Minimum 90mm outlet pipe.

APD's StormPit range offers more than just compliance to NZBC E1, we have designed additional features to benefit the installer onsite and ensure the long-term, trouble-free use.

## ADDITIONAL FEATURES

- 5 tonne rated ductile iron grate fits into the main body for shallow depth installations.
- Adjustable in height from 171mm – 445mm from top of outlet pipe to finished ground level.
- 274mm of height adjustment.
- 3 x Moulded inlet connections sized for 100mm PVC.
- Full 100mm sized outlet with oversized trap for greater flow.
- Anti-flotation ring.
- No threads that can bind up with gravels and fines.
- Easy to remove access cap.

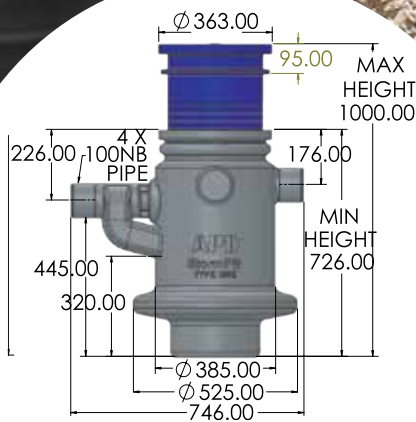

Producer Statement 1  
is available from  
[www.apd.co.nz](http://www.apd.co.nz)

For more information call (09) 263 7741

[www.apd.co.nz](http://www.apd.co.nz)

# StormPit 250

If larger sumps need to meet NZBC E1 then why not make sure your smaller sumps meet the same requirements.

LIKE ITS BIG  
BROTHER, OUR  
250MM VERSION IS  
**EASIER!**  
**FASTER!**  
**IMPROVED!**



## ADDITIONAL FEATURES

- 1 tonne rated ductile iron grate fits into the main body for shallow depth installations.
- Adjustable in height from 132mm – 392mm from top of outlet pipe to finished ground level.
- 260mm of height adjustment.
- 1 x Moulded inlet connection sized for 100mm PVC.
- Full 100mm sized outlet with oversized trap for greater flow.
- Anti-flotation ring.
- No threads that can bind up with gravels and fines.
- Easy to remove access cap.

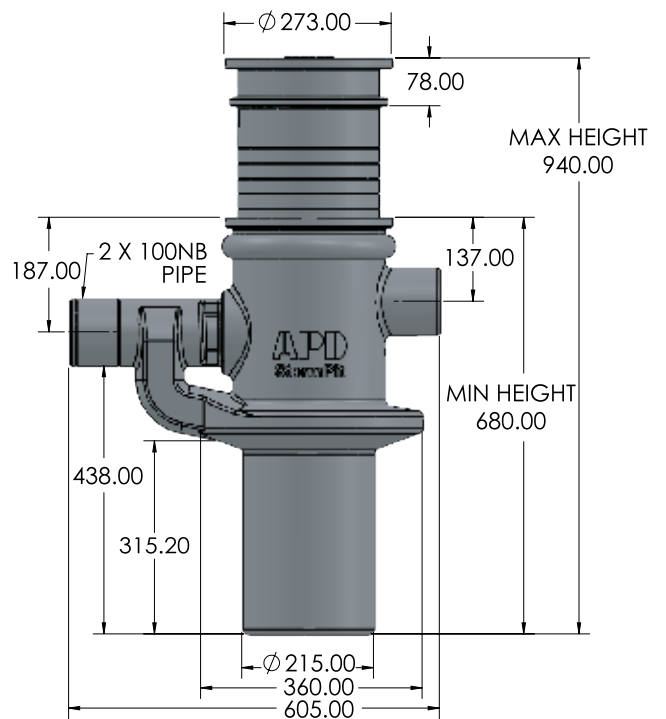

For more information call (09) 263 7741

[www.apd.co.nz](http://www.apd.co.nz)

# StormPit Type Two

Why use heavy, difficult concrete sumps when you can use a New Zealand building code compliant APD Type Two sump and make your job easier?



## BENEFITS

- Lightweight, sump and riser are only 45kg - an easy two person lift.
- Will fit a range of Class D 600mm opening round grates.
- Rectangular grates are also available in both flat and concave Class D.
- Anti-flotation ring, no additional concrete required.
- Made in NZ of durable recyclable polyethylene.
- Manufactured from water tank grade PE material suitable for below ground installations.
- Producer Statement 1 is available from [www.apd.co.nz](http://www.apd.co.nz)

**LIGHTER!  
EASIER!  
FASTER!**

For more information call (09) 263 7741

[www.apd.co.nz](http://www.apd.co.nz)

# StormPit Type Two

Lightweight, and made in New Zealand from durable recyclable polyethylene, APD StormPit Type Two sumps are available with circular and rectangular (flat or concave) grates to best suit your site.

## RECTANGULAR GRATE OPTIONS



CONCAVE GRATE



FLAT GRATE

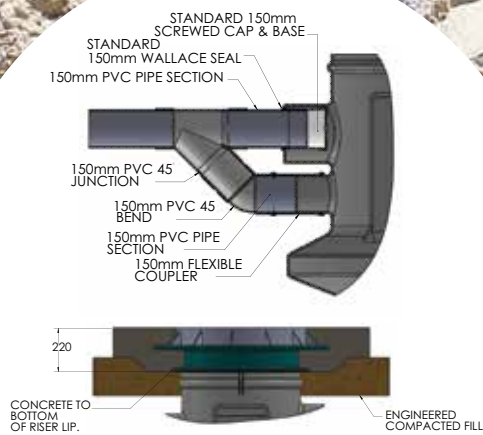

## FEATURES

- Moulded in lifting eyes if required.
- Adjustable in height from 1270mm – 1520mm from the base of the unit to FGL.
- Ability to easily install 150mm UPVC syphon with access cap.
- 1 x 250mm OD spigot, 2 x 160mm OD (150mm UPVC) spigots and 2 x flat panels for multiple inlet or outlet locations.
- Easy cutting with hole saw and use of 150mm rubber seals.
- 250mm of height adjustment.
- Easy height identification marks for cutting and drilling.

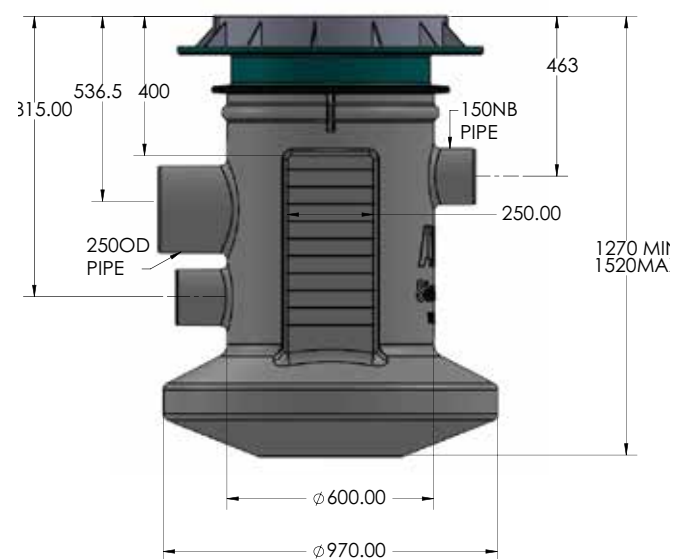

For more information call (09) 263 7741

[www.apd.co.nz](http://www.apd.co.nz)

# StormPit Bubble Up

## THE APD StormPit BUBBLE UP MAKES YOUR JOB EASIER!

The APD StormPit Bubble Up chamber is designed to meet all the NZBC requirements, with multiple features to benefit the installer onsite and ensure long-term, trouble-free use.

**EASIER!  
FASTER!**

## ADDITIONAL FEATURES

- Adjustable in overall height from 835mm – 1010mm.
- Moulded garden lid with fixings.
- 175mm of height adjustment.
- 2 x flat panels for easy installation of pipe and seals to the required height.
- 2 x 100mm Wallace seals provided.
- Anti-flotation ring, no additional concrete required.
- Easy height identification marks for cutting and drilling.
- Made in NZ of durable recyclable polyethylene.
- Manufactured from water tank grade PE material suitable for below ground installations.
- Outlet can be put through the Riser section using the Wallace seal.
- Garden & pavement (Ductile Iron) lids available for the Distribution Chamber.

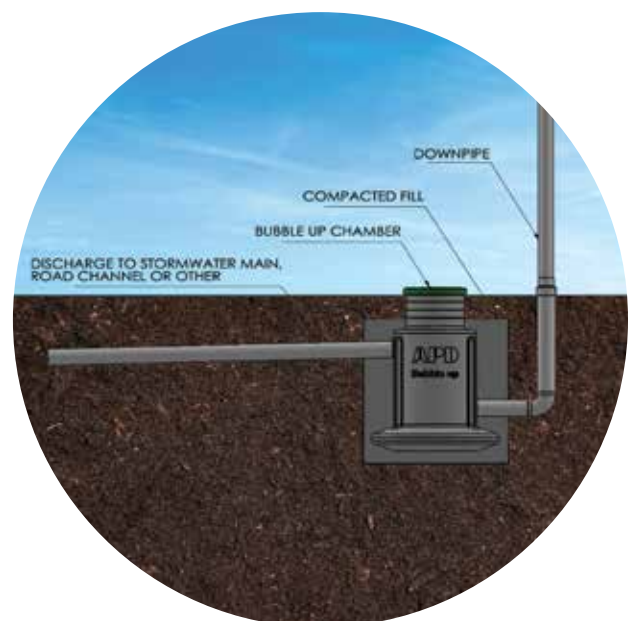

For more information call (09) 263 7741

[www.apd.co.nz](http://www.apd.co.nz)

# StormPit Bubble Up

## THE APD StormPit BUBBLE UP MAKES YOUR JOB EASIER!

The APD StormPit Bubble Up chamber is designed to meet all the NZBC requirements, with multiple features to benefit the installer onsite and ensure long-term, trouble-free use.

**EASIER!  
FASTER!**

### STANDARD UNIT WITH GARDEN LID

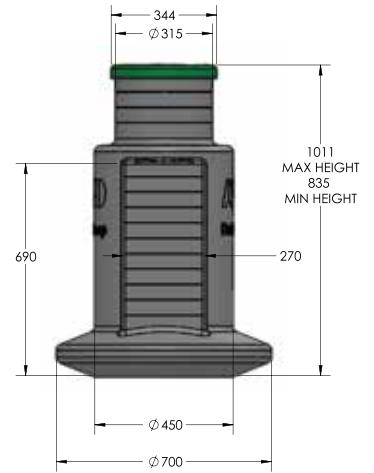

### DUCTILE IRON LIDS AVAILABLE IN ROUND OR SQUARE FORMATS

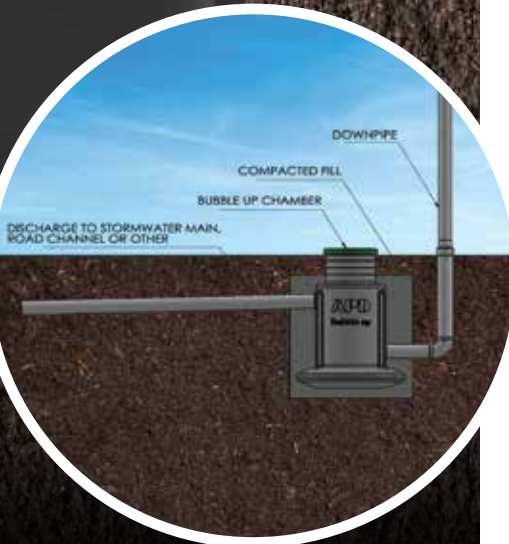











For more information contact  
your APD account manager  
or call (09) 263 7741

[www.apd.co.nz](http://www.apd.co.nz)

November 2023